

6' Free Standing Picnic Table

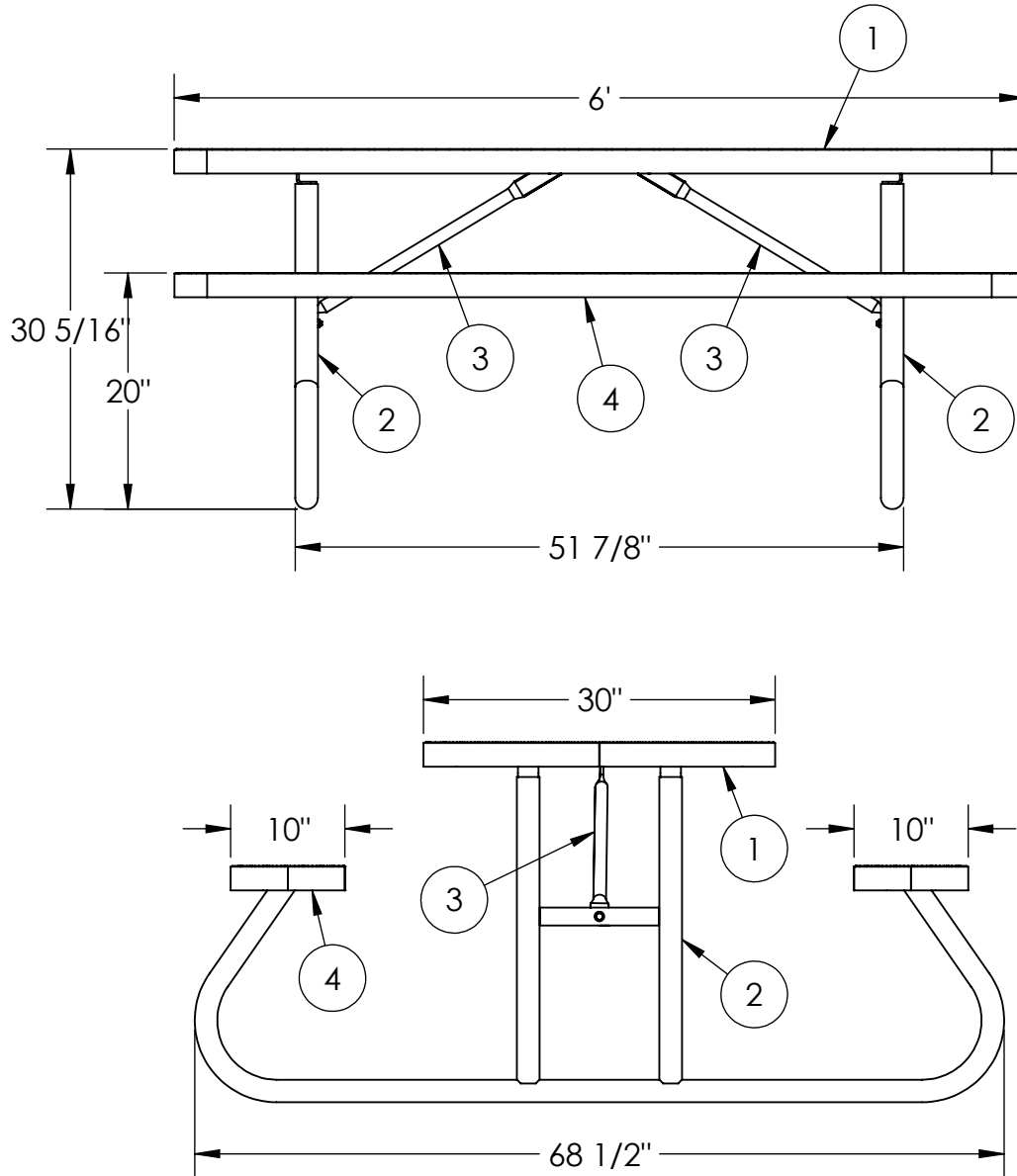

ITEM NO.	DESCRIPTION	QTY.
1	6' Table Top	1
2	Free Standing Table Stand For Seats	2
3	TABLE BRACE	2
4	Seat/Back 6'	1
5	3/8"x1-1/2" SS Hex Bolt	14
6	3/8" SS Flat Washer	28
7	3/8" SS Nylock Nut	14

6' Free Standing Picnic Table

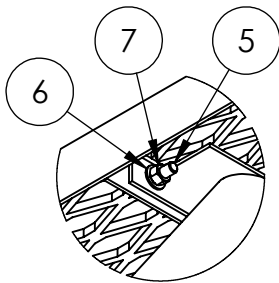
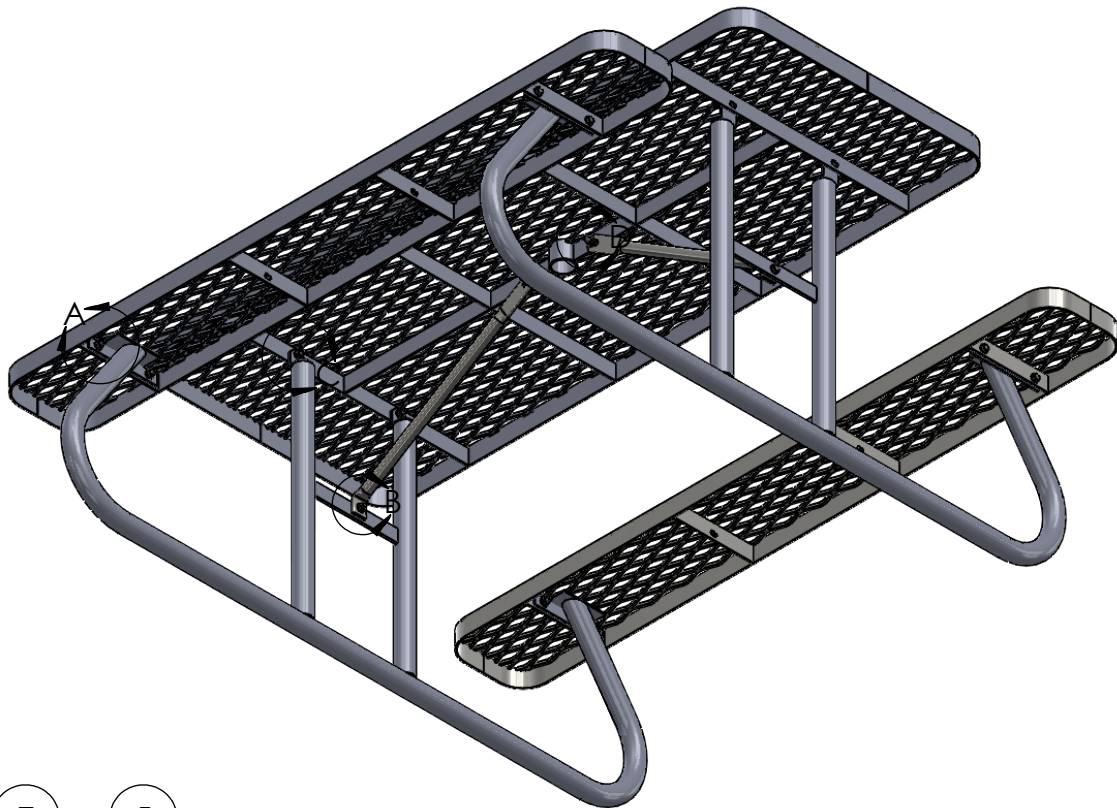

DETAIL A
SCALE 1 : 6

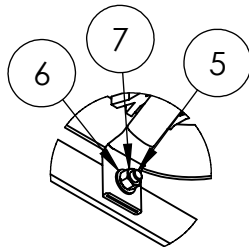

DETAIL B
SCALE 1 : 6

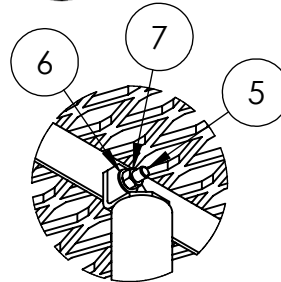

DETAIL C
SCALE 1 : 6

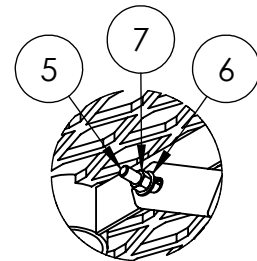

DETAIL D
SCALE 1 : 6

1. Drill out holes.
2. Attach both stands to the inside of table support bar. (See diagram above)
3. Attach the seats to the stands.
4. Attach the straight end of each brace to the table. (See diagram above)
5. Attach bent end of both braces to the cross bar of each stand. (See diagram above)

Tools List

- 7/16" Drill bit
- 9/16" Socket
- 9/16" Wrench
- 7/32" Allen Wrench
- Drill

Periodic check of bolts tightness recommended

In accordance to California law: WARNING - This product contains a chemical known to the State of California to cause cancer and birth defects or other reproductive harm.