

PRKITSMS Total Coat Square & Round Picnic Table Surface Mount Conversion Kit

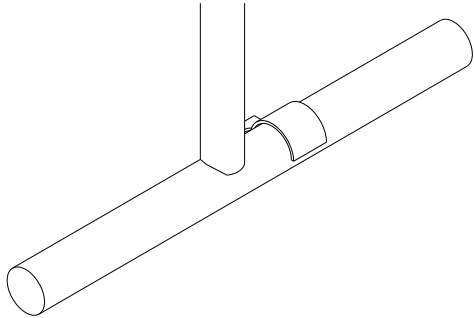

Description	Qty.
Large (Small) Clamp	2
3/8"x3-3/4" SS Concrete Anchor W/washer & nut	2

- 1 Position Bench in desired location and mark location of anchor bolts.
- 2 Drill hole in concrete using a 3/8" masonry bit. The hole should be at least 1-5/8" deep. (see illus. 1)
- 3 Clean the debris from the hole and check the depth.
- 4 Assemble the nut and washer. Drive the anchor through the hole in the clamp. (see illus. 2)
- 5 Tighten the nut 3 to 5 turns to expand the anchor. (see illus. 3)

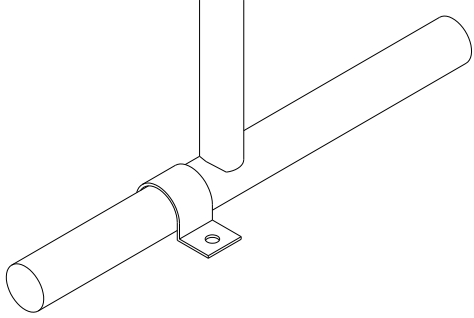